



MOBILE CONDUCTOR RAIL



WAKAI
MOBILE CONDUCTOR RAIL

Energy and data transmission WAKAI Mobile Conductor Rail



WAKAI conductor rail system delivers many advantages of your preferred power supply at work. Enhance your work efficiency with safety, convenience and reliability !!

This conductor electric rail system is designed by the safety workplace concept. It is manufactured to reach high safety, high quality and easily installed. Many ways of applications with low maintenance cost. With the idea of applying continuous copper strips will ensure your working condition runs smoothly, efficiently and economically.

GENERAL WORKING CONDITIONS

Operating voltage	up to 600V
Operating temperature	- 30°C + 55°C (- 22 ° F + 130 ° F)
Travel speed	250 metre / min.

PLASTIC HOUSING TECHNICAL DATA

Specific weight	1.43 kg/ dm ³
Deformation temperature	81°C
IZOD @ 25°C	9 kg/cm ²
Tensile Strength 3	460 kg/cm ²

COPPER STRIP TECHNICAL DATA

CURRENT RATING AMP	CONDUCTOR CROSS SECTIONAL AREA	RESISTANCE Ω/m.	IMPEDANCE Ω/m. (50 Hz.)	VOLTAGE DROP V/m./Amp.	UNIT WEIGHT Meter / Kg.
60	14.0 mm ²	0.0019	0.0019	0.0033	8.04
100	25.2 mm ²	0.0010	0.0012	0.0021	4.46
125	28.0 mm ²	0.0006	0.0008	0.0014	4.01
160	36.4 mm ²	0.0005	0.0006	0.0010	3.09

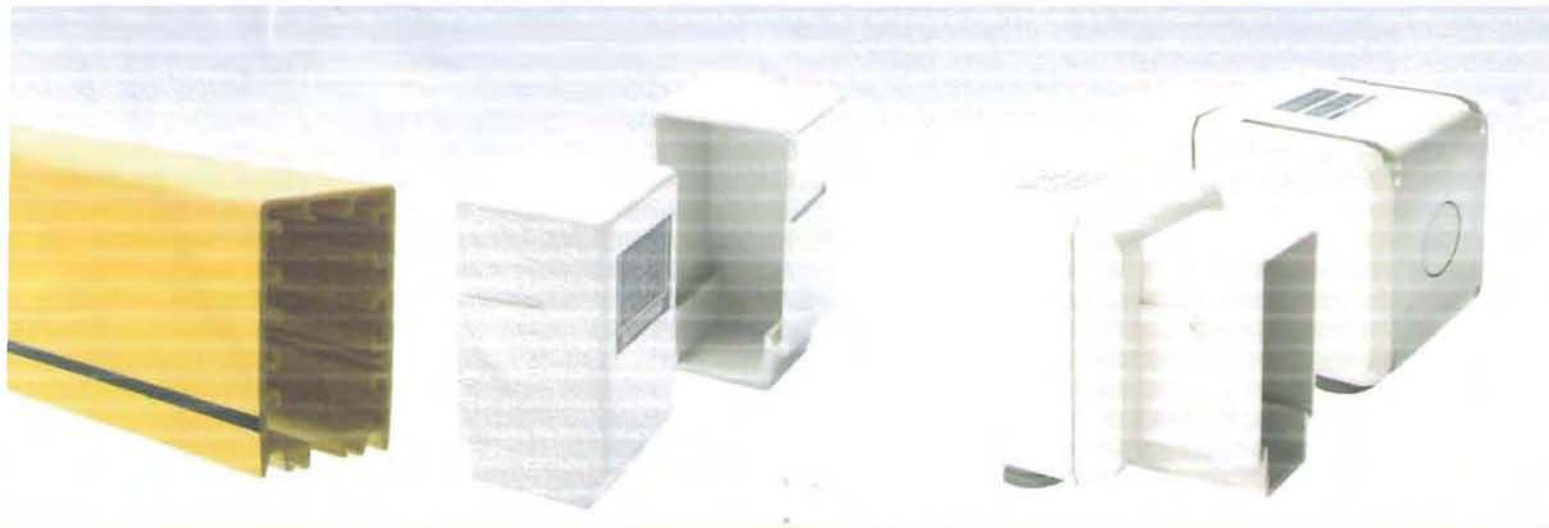

Conductor Housing	End Cap	End Feed
<p>Material : PVC Length : 4 meters Poles : 7 slots with ground strip line and 2 protection seal slots Power : up to 300 amps by double current 1-EPR-ST-702</p>	<p>Material : ABS 1-ECP-01-003</p>	<p>Material : ABS Poles : ready 7 slots Power : up to 300 amps by double current 1-EFD-01-003</p>

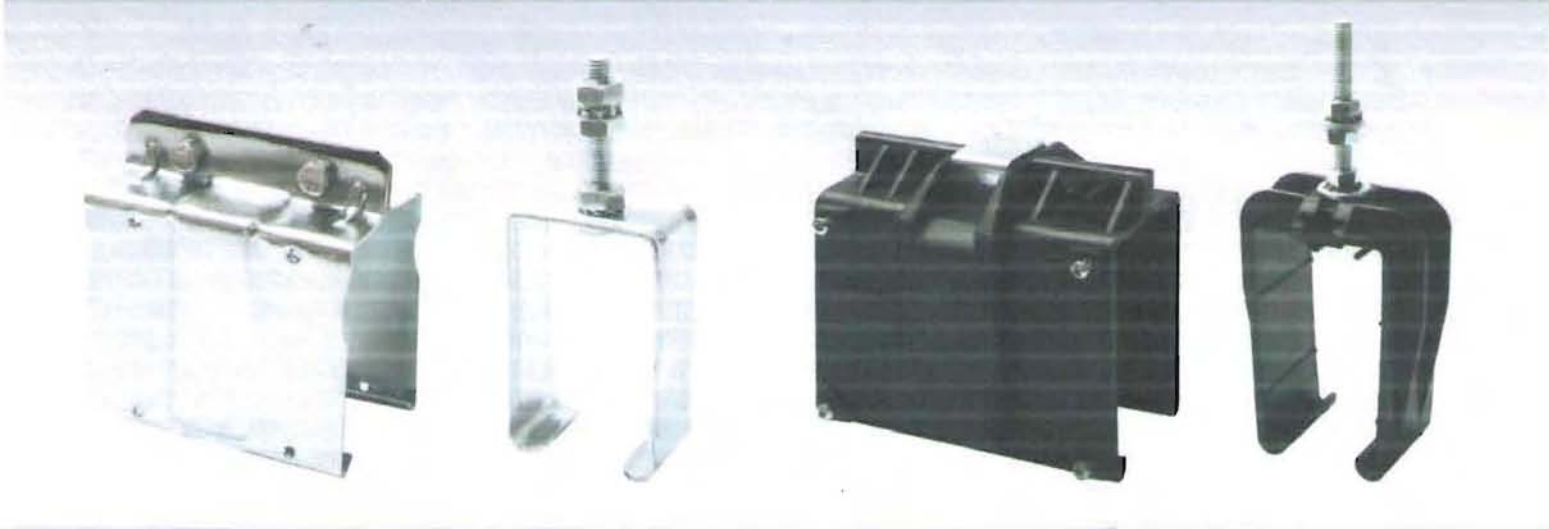

Steel : Joint Cover	Sliding Hanger	Plastic : Joint Cover	Sliding Hanger
<p>Material : Zinc Coated Steel 1-EPR-ST-702</p>	<p>Material : Zinc Coated Steel 1-SHG-GS-101</p>	<p>Material : PA66 1-CNP-PF-301</p>	<p>Material : PA66 1-SHG-PA-301</p>



Plastic Joint Cover

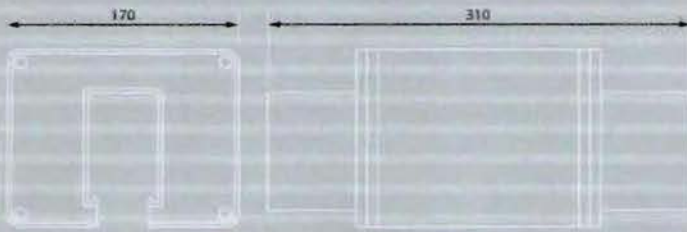

Material : ABS
Poles : ready 7 slots
Power : up to 300 amps by double current

4 SLOTS 1-LFD-01-401
 7 SLOTS 1-LFD-01-701

Arm set

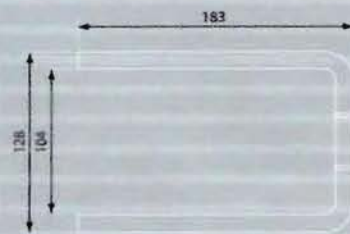

Material : Aluminium

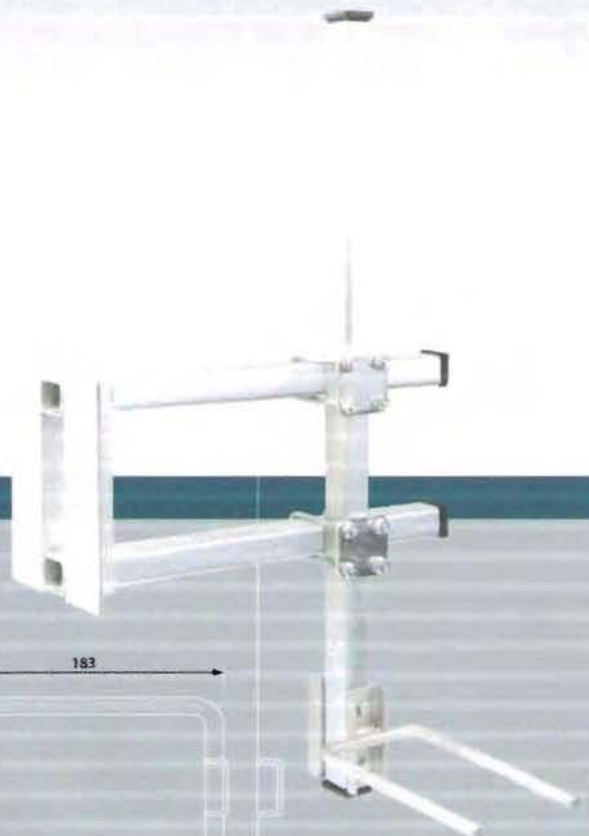

Fix Point Camp

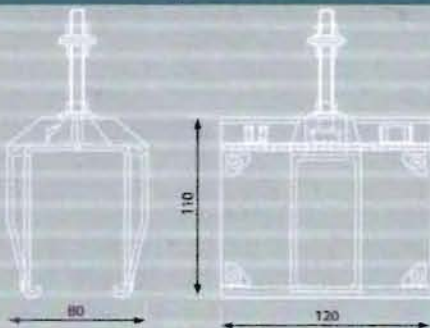

Material : PA66



Single Collector

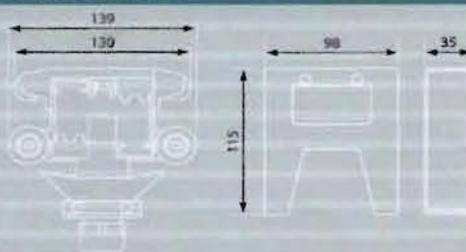

Material : PVC
TYPE : 35 A 4 poles

1-CLN-46-1-20



Double Collectors with bracket

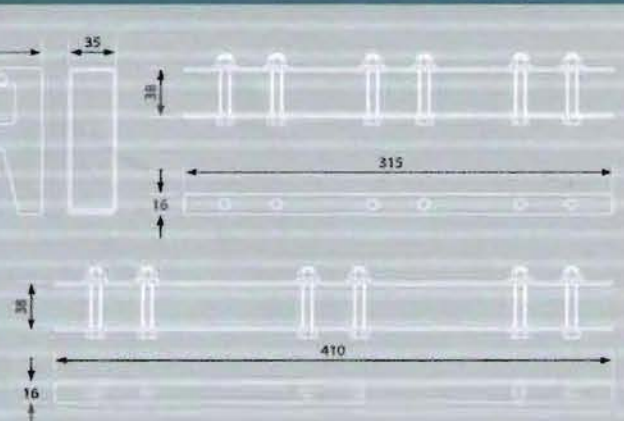

WAKAI SYSTEM CHARACTERISTIC FEATURES

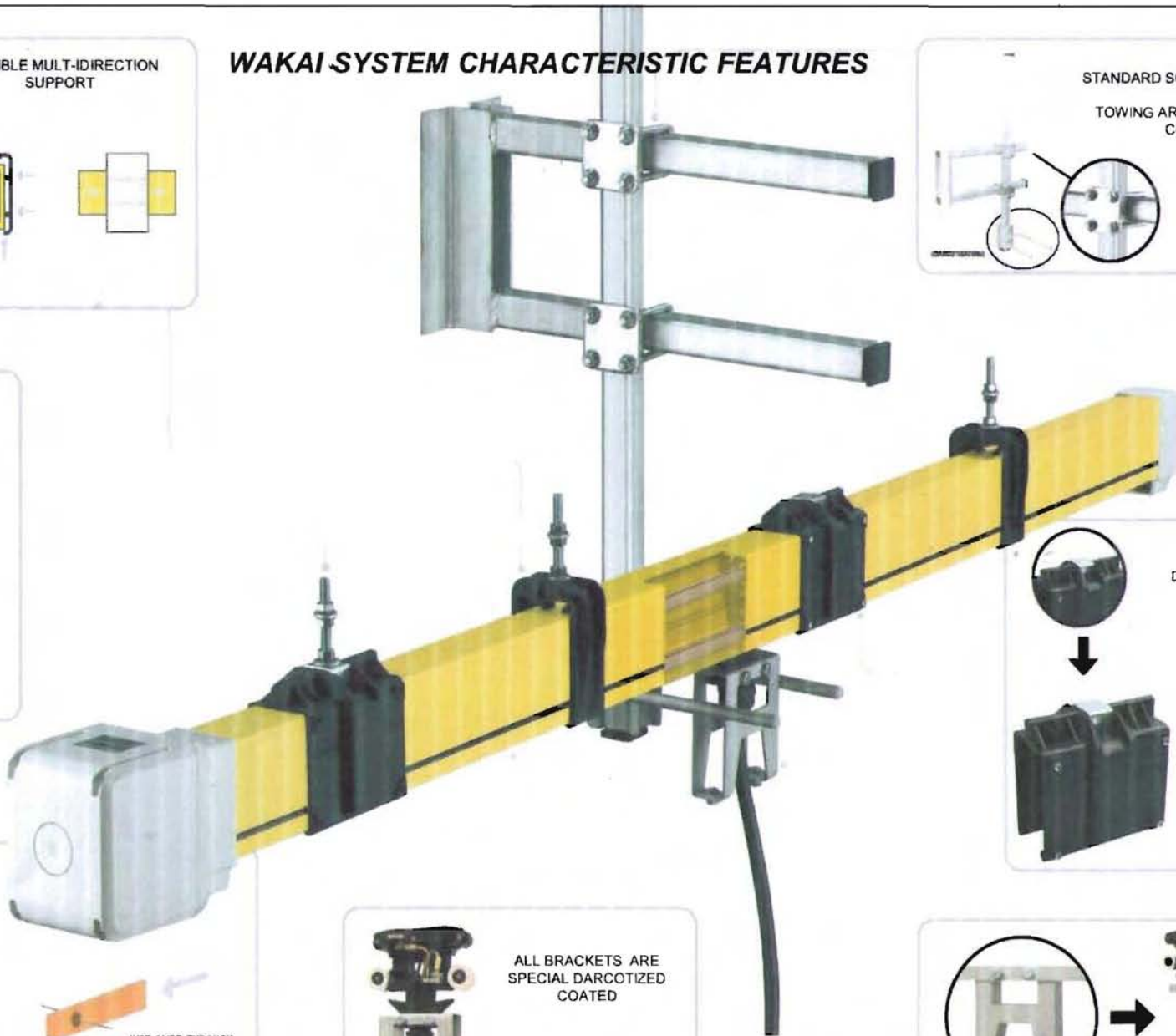
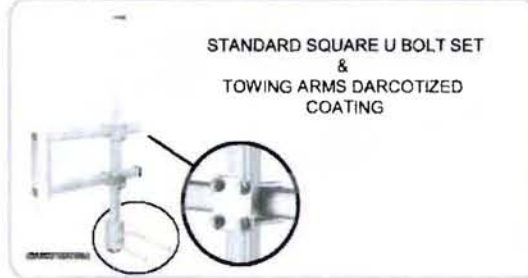
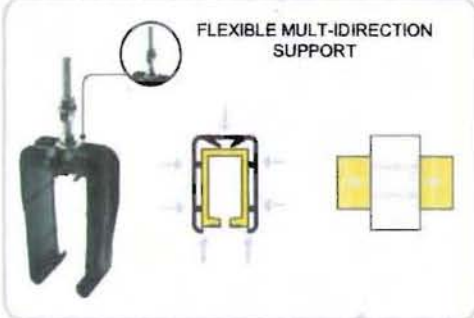

Energy and data transmission : WAKAI Mobile Conductor Rail



FIX POINT CLAMP INSTALLATION

Apply the screw set with joint cover and metal clip at the top-center of the cover

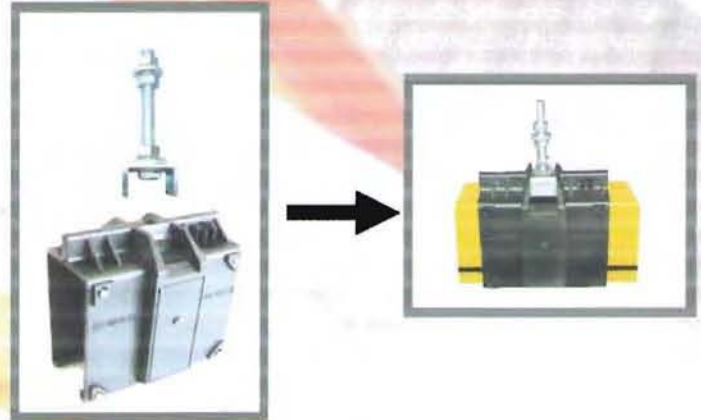

COLLECTOR TROLLEY INSTALLATION

With this convergent design, only one **Towing Arm Set** surely fits to every collector sets. Economic price with efficient performance.

SINGLE COLLECTOR :

Apply a collector trolley with a set of bracket, place the arm cover both left and right side of the frame

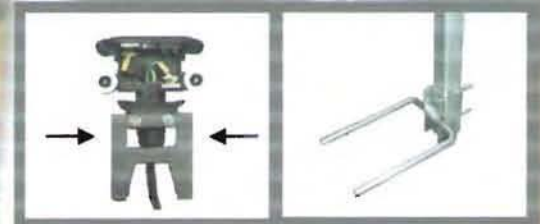

DOUBLE COLLECTORS :

Apply 2 collector trolleys with a set of bracket, with type 2 connector bar, place the arm cover both left and right side of the frame.



TRIPLE COLLECTORS :

Apply 3 collector trolleys with a set of bracket, with type 3 connector bar, place the arm cover both left and right side of the frame.

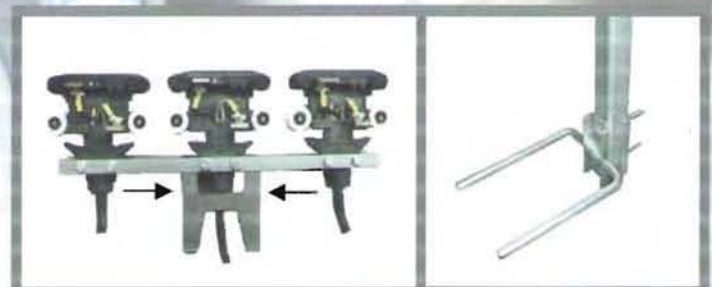

Energy and data transmission : WAKAI Mobile Conductor Rail



END FEED SET INSTALLATION

With the special design End-Feed set, there's no need to bend the copper strip. Just pull the strips to determine position and then tighten the bolt and the connector together. More safety on the work place, Less time to finish !!

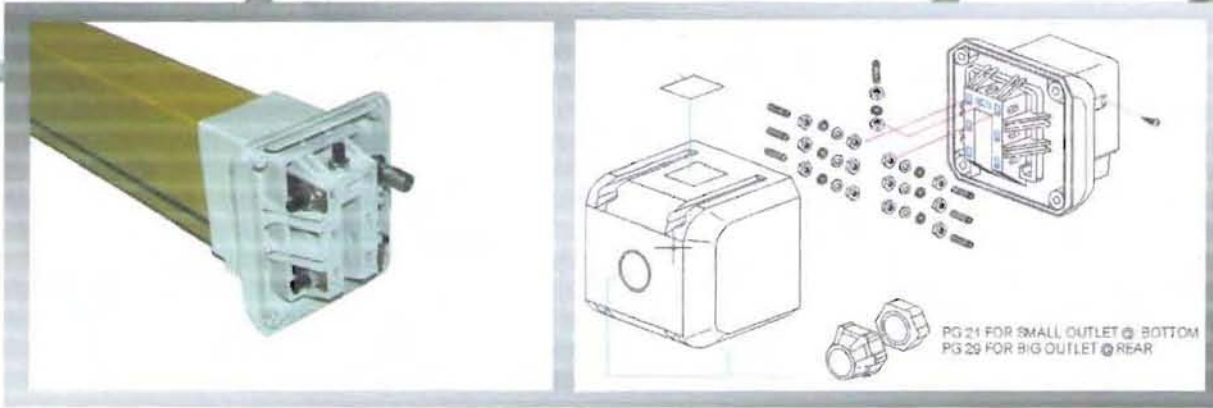

IN-LINE FEED SET INSTALLATION

Prepare the covers and connectors before pulling the copper strips. Pull the strips through the legs of the connectors. Tighten all screws and bolts.

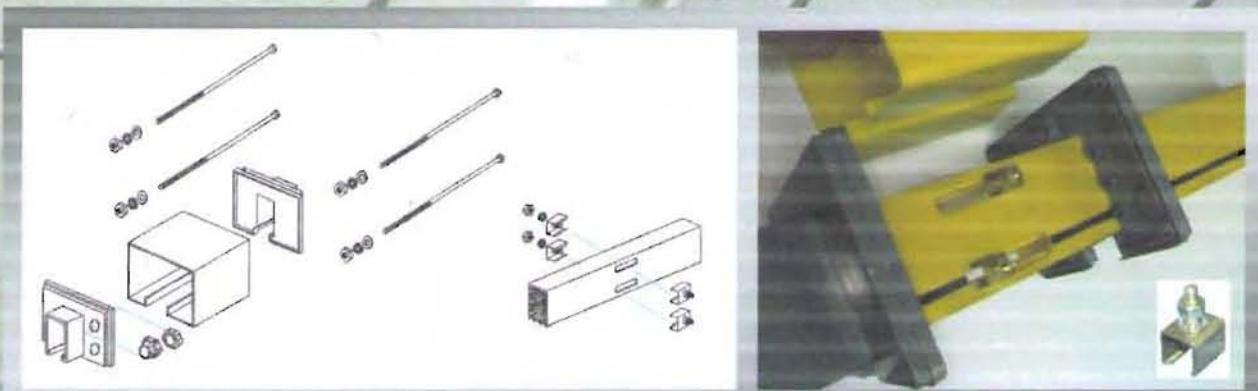

COPPER STRIPS (CONDUCTOR) INSTALLATION

- Drill the 6 mm. diameter hole at the end of the strip.
- Place one of the track length copper strip rolls in the pulling-cassette/plate supplied.
- Fasten the copper strip to pulling attachment. Generally, bend the end of the strip a few degree outwards to the side of the rail would be easier to pull.
- Pull the strips from the end of the line through the slots by means of a rope until the bent end of the strip pass over Feed box slot (make sure that the strip holes are in the range of the feed box slot)

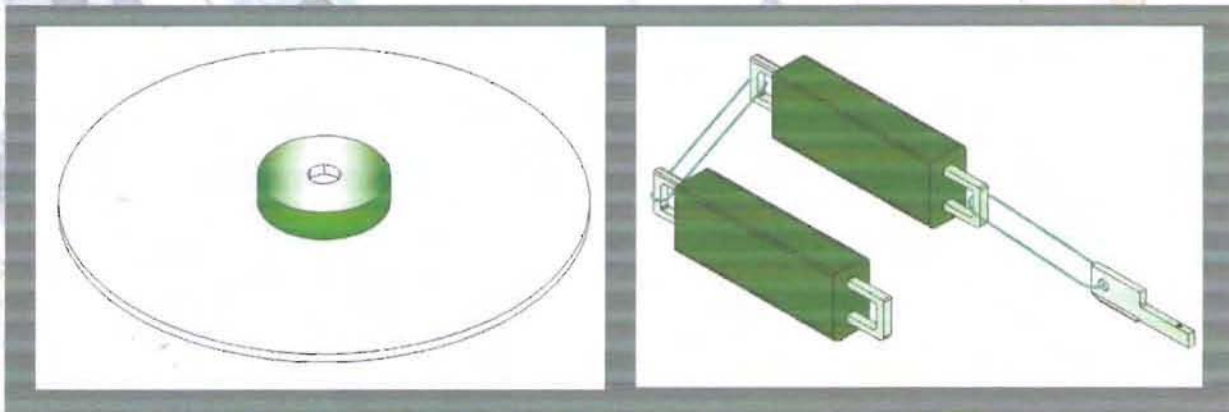

PULLING – CASSETTE

PULLING – BLOCK

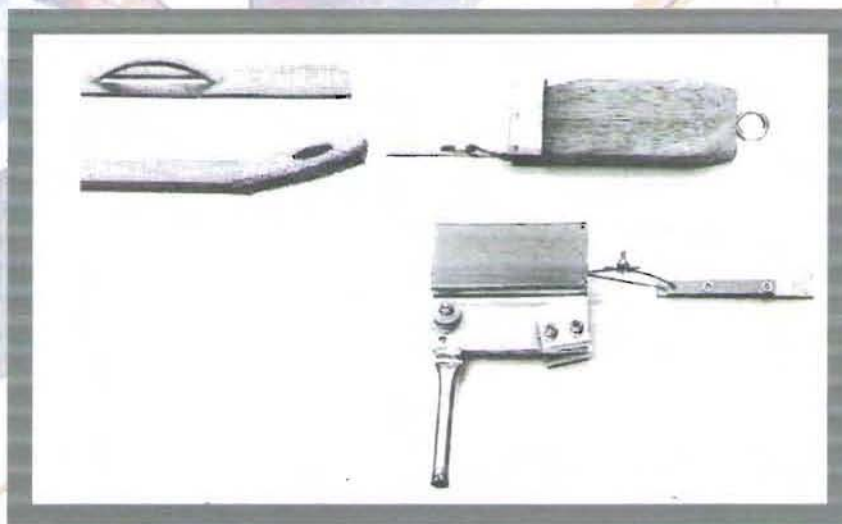

PULLING HEAD TOOL SET

BRACKET (CONDUCTOR) INSTALLATION

SINGLE COLLECTOR TYPE

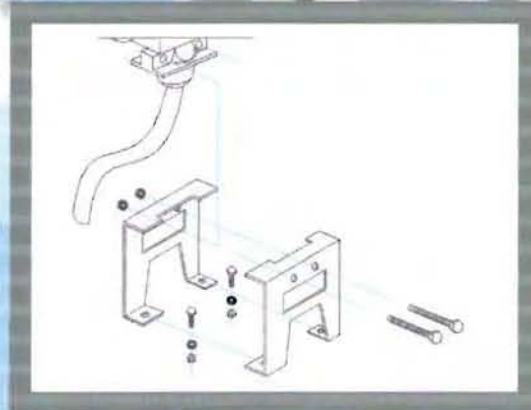

- PLACE THE CENTER OF THE BRACKET HOLES TO THE CENTER OF THE COLLECTOR HOLES.
- EACH BRACKET HAS IDENTICAL SHAPE, SO ONE LEG OF IT IS ABOVE ANOTHER, ONE LEG IS UNDER THE OTHER SIDE.
- TIGHTEN THE BOLT (M8) TO THE COLLECTOR THEN TIGHTEN THE BOLT AT THE LEGS.

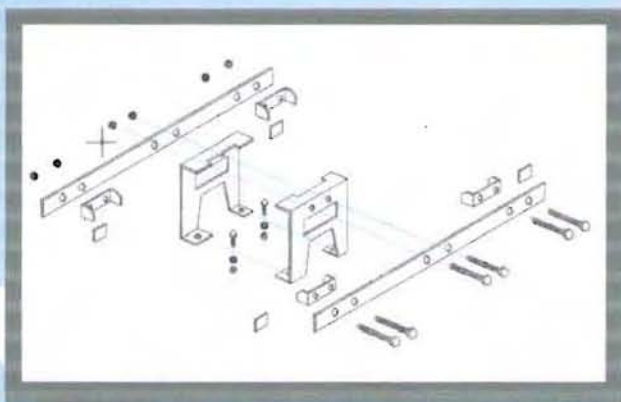

DOUBLE & TRIPLE COLLECTOR TYPE

- FOLLOW THE SINGLE TYPE PROCEDURE
- PLACE THE CONNECTION BARS AS IN THE PICTURE
- ASSURE THAT THE HOLES OF COLLECTOR ARE IN THE SAME CENTER OF THE BAR
- DOUBLE TYPE, BOTH COLLECTORS ARE AT THE END OF THE BAR
- TRIPLE TYPE, 3 OF THEM ARE ON THE POSITIONED HOLES (LIKE SINGLE TYPE BUT 2 MORE COLLECTORS AT THE RIM)

END-FEED TYPE INSTALLATION DIAGRAMS

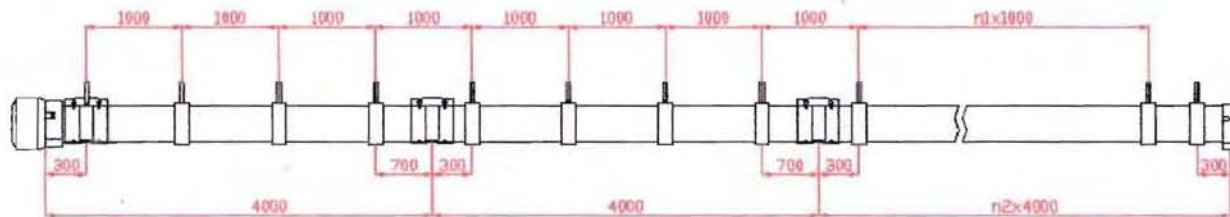

1 METER SUPPORT

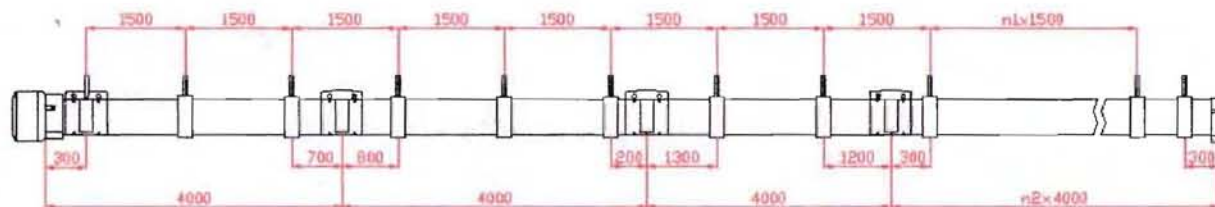

1.5 METER SUPPORT

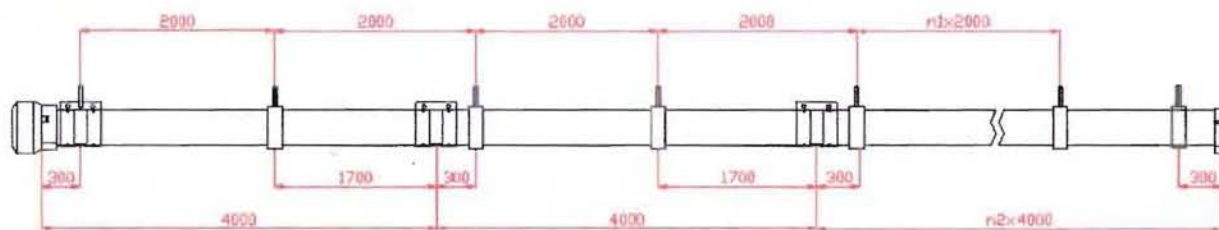

2 METER SUPPORT



VARIED WORKING APPLICATIONS IN MANY CONDITIONS

